

City of Easley
Department of Planning and Development
Planning Commission Meeting
June 15, 2026

Staff Report

Case Number: PLN-ANN-26-04

Applicant: David Odom, PE

Property Owner: Latham Road LLC

Parcel ID's: 5039-16-84-8206

Acreage: 13.16

Proposed Zoning: Office / Institutional (OI)

Proposed Future Land Use: Commercial

Surrounding Property:

Current Zoning: North: County – Vacant Land
East: County – Commercial
South: Railroad ROW
West: General Residential 2 (GR-2) / General Commercial (GC)

Future Land Use: North: County
East: County
South: Railroad ROW
West: Commercial

Summary of Request

Summary of Request

David Odom, PE, on behalf of Latham Road LLC, is requesting the annexation of approximately 13.16 acres from Tax Parcel 5039-16-84-8206 into the City of Easley with a proposed zoning designation of Office/Institutional (OI) and a Future Land Use designation of Commercial.

The applicant proposes to develop the site as a public charter school serving approximately 1,000 students from Pre-K through 8th Grade. Charter schools are publicly funded educational institutions and do not charge tuition for attendance. The subject property is part of a larger 38.94-acre parcel that is divided by Highway 153 into two separate tracts. The current

annexation and rezoning request applies only to the approximately 13.16-acre portion of the property.

The property is bordered by vacant land within Pickens County to the north, commercial uses within Pickens County to the east, a railroad right-of-way to the south, and a mixture of General Residential-2 (GR-2) and General Commercial (GC) zoning within the City of Easley to the west. The proposed Office/Institutional zoning designation is intended to accommodate educational, governmental, medical, and similar institutional uses and is compatible with the proposed charter school development.

Some residents have expressed concerns regarding continued population growth in the Upstate region and the potential impact on local schools. While staff has not independently verified enrollment capacities within the School District of Pickens County, the proposed charter school would provide an additional educational option for families within the region. According to publicly available rankings, South Carolina ranks near the lower half of states nationally in educational performance, while the School District of Pickens County has been recently recognized as one of the stronger performing school districts within the state.

A conceptual site plan has been submitted by the applicant to illustrate the general intent of the proposed school campus and associated circulation patterns. However, the site plan has not received formal development approval and remains subject to additional review and modification. Approval of this annexation and rezoning request does not constitute approval of a site plan, subdivision, or development permit.

A Traffic Impact Analysis (TIA) has been completed and submitted to the South Carolina Department of Transportation (SCDOT) and the Office of School Facilities (OSF) for review. The study identified several transportation improvements intended to mitigate projected traffic impacts associated with the proposed development, including:

- Construction of a northbound right-turn lane on Rolling Hills Circle at Access A with 150 feet of storage and appropriate taper.
- Construction of dual westbound left-turn lanes on US 123 at Prince Perry Road/Rock Springs Road with a minimum of 250 feet of storage.
- Widening of Rock Springs Road to provide an additional southbound receiving lane extending to Dayton School Road.
- Modification of the signal plan at US 123 and Prince Perry Road/Rock Springs Road to accommodate the proposed roadway improvements.
- Installation of protected/permitted left-turn phasing for the westbound approach of Rolling Hills Circle at Town Center Way.

The recommendations contained within the Traffic Impact Analysis are currently under review by SCDOT and OSF. Any roadway improvements ultimately required by SCDOT, the Office of School Facilities, or other reviewing agencies shall be the responsibility of the applicant.

Should the annexation and rezoning be approved by Planning Commission and City Council, any future development proposal will be subject to additional review by City staff and applicable state agencies. Future development will be evaluated for compliance with the Unified Development Ordinance, including site design, buffering, lighting, landscaping, stormwater management, traffic circulation, emergency access, and other development standards.

Comprehensive Plan Consistency

The proposed annexation and Office/Institutional (OI) zoning designation are generally consistent with the City of Easley Comprehensive Plan. The Land Use Element encourages the annexation of neighboring properties and supports managed growth through coordinated development and infrastructure planning. The Comprehensive Plan further recognizes the importance of maintaining high-quality community facilities and public services as the City continues to grow.

The Community Facilities Element emphasizes the need to plan for future educational facilities and public services necessary to accommodate projected population growth. The proposed charter school would expand educational opportunities within the region while locating a community-serving institutional use adjacent to existing transportation infrastructure and commercial development.

The proposed Office/Institutional zoning district is compatible with surrounding land uses and supports the Comprehensive Plan's goals related to community facilities, managed growth, economic investment, and the orderly extension of municipal services.

Staff Recommendation

Based on the property's location adjacent to existing commercial development, the suitability of the Office/Institutional zoning district for the proposed educational use, the applicant's commitment to addressing transportation impacts through the Traffic Impact Analysis process, and the request's consistency with the goals and recommendations of the City of Easley Comprehensive Plan, staff recommends approval of PLN-ANN-26-04.

Respectfully submitted,

A handwritten signature in black ink that reads "Corey Holycross". The signature is written in a cursive, flowing style.

City Planner

Exhibits:

Exhibit A: Zoning Map

Exhibit B: Future Land Use Map





Exhibit C: Application

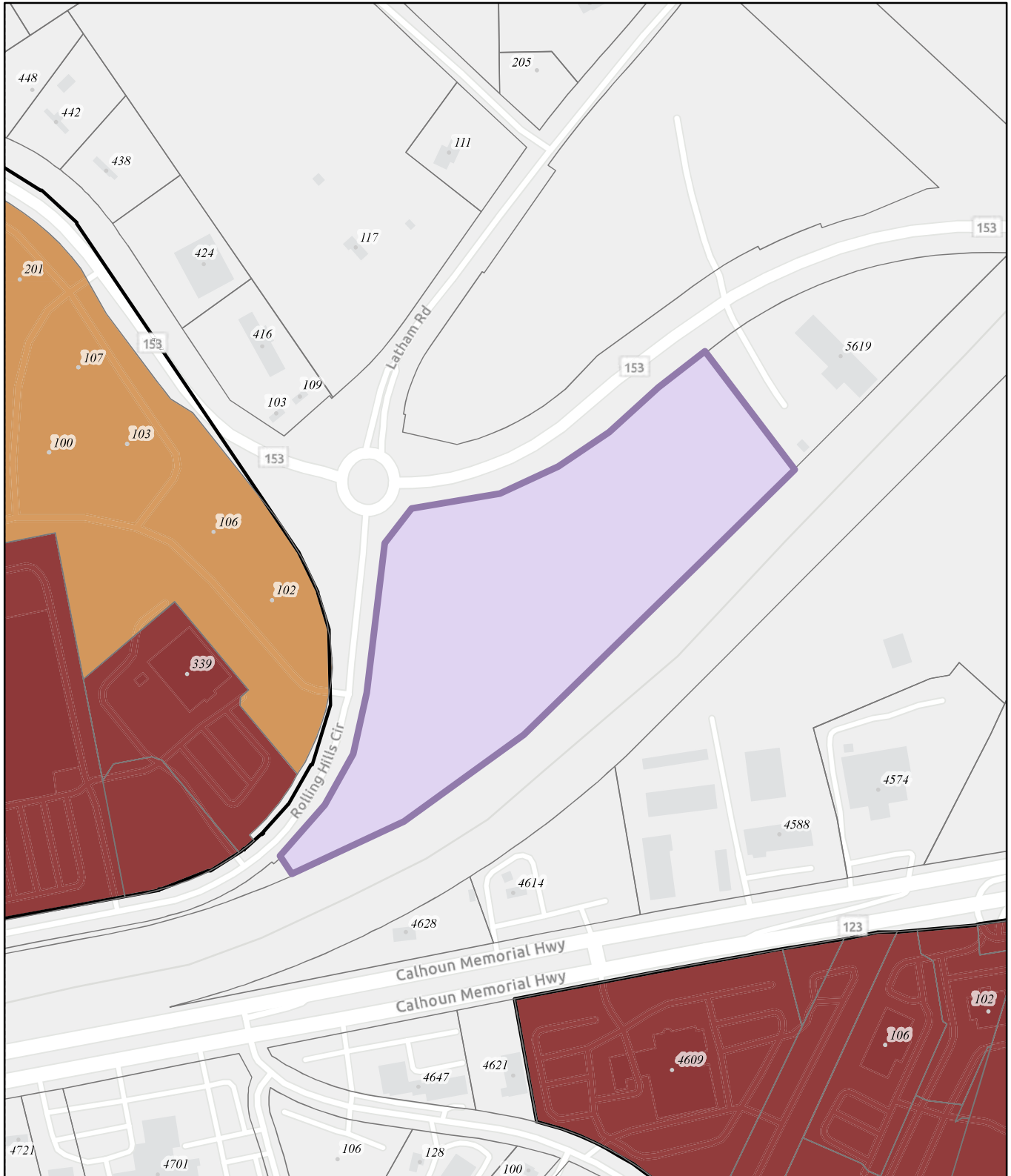

Exhibit D: Traffic Impact Analysis

Zoning - PLN-ANN-26-04



6/9/2026, 12:03:06 PM

-  County Boundary
-  Address Points
-  Pickens County Parcels
-  City Limits

- Zoning**
-  General Residential 2 (GR-2)
 -  General Commercial (GC)

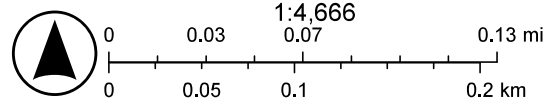

Sources: Esri, TomTom, Garmin, (c) OpenStreetMap contributors, and the GIS User Community, Sources: Esri, TomTom, Garmin, FAO, NOAA, USGS, (c) OpenStreetMap contributors, and the GIS User Community

FLU - PLN-ANN-26-04

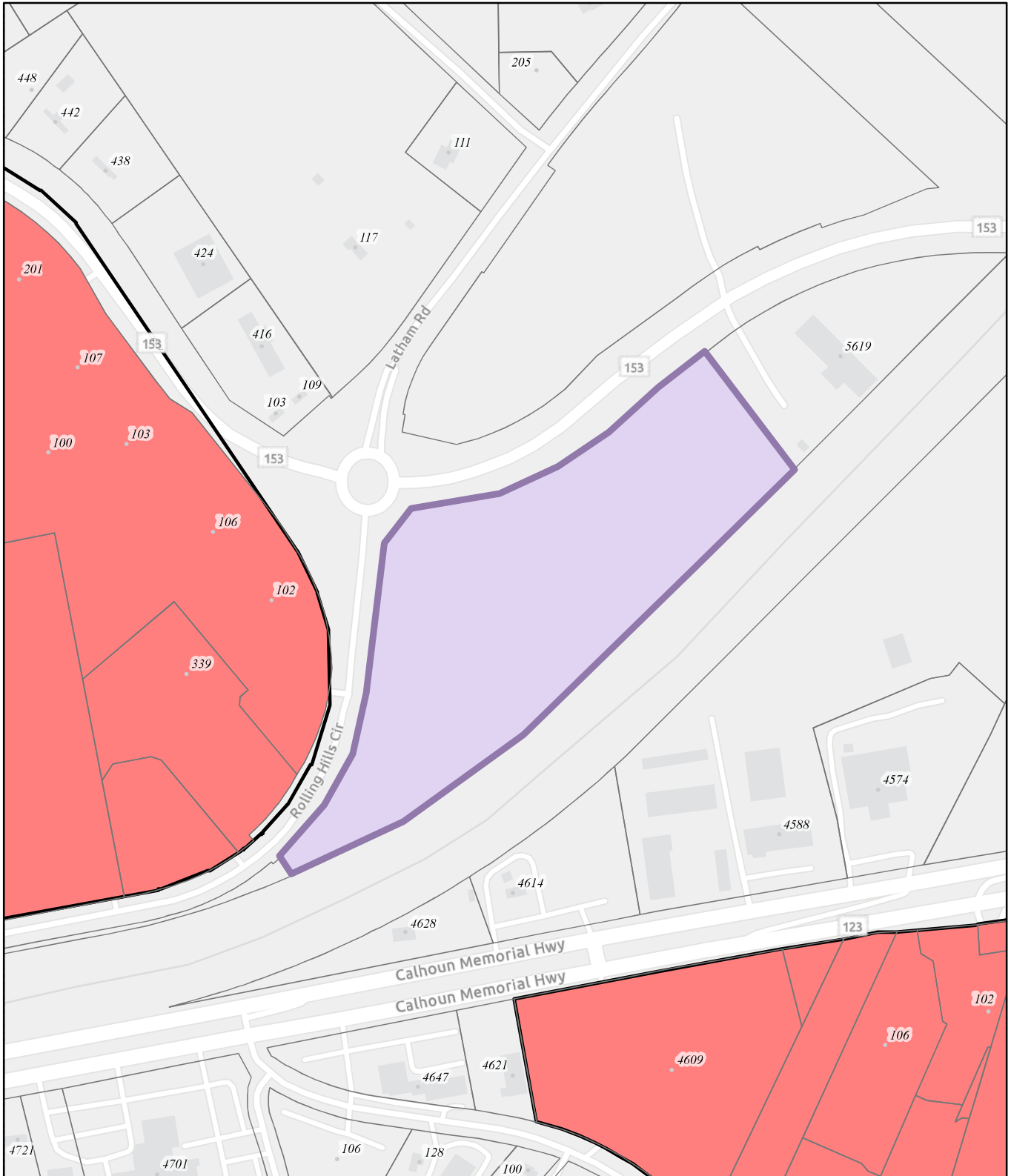

6/9/2026, 12:02:37 PM

- County Boundary
- City Limits
- Address Points
- Future Land Use
- Commercial
- Pickens County Parcels

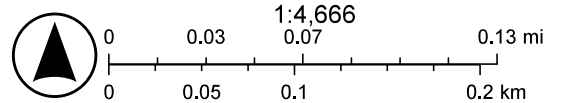

Sources: Esri, TomTom, Garmin, (c) OpenStreetMap contributors, and the GIS User Community, Sources: Esri, TomTom, Garmin, FAO, NOAA, USGS, (c) OpenStreetMap contributors, and the GIS User Community



APPLICANT/OWNER INFORMATION

*Indicates Required Field

	APPLICANT	PROPERTY OWNER
*Name:	David Odom, PE	Latham Road LLC
*Title:	Civil Engineer	Partnership
*Address:	169 Oak St	205 Cabin Road
*City, State:	Forest City, NC	Easley, SC
*Zip:	28043	29640
*Phone:	828-247-4495	864-704-3662
*Email:	David@odomengineering.com	ddgaston77@gmail.com

LEGAL REPRESENTATIVE (if applicable)

Name:	
Title:	
Address:	
Phone:	
Email:	

PROPERTY INFORMATION

*PARCEL #(S) 5039-16-84-8206

*TOTAL ACREAGE 13.8

*CURRENT ZONING DESIGNATION (County) Commercial

*PROPOSED ZONING DESIGNATION (City) OI - Office-Institutional

TYPE OF ANNEXATION

*Please select one (1) type: 100% 75% 25%

For 100% and 75% Annexations, please Include the corresponding **Annexation Petition** with the application submittal.

INSTRUCTIONS

1. The applicant is strongly encouraged to schedule a pre-application conference with the Zoning Administrator prior to the scheduled submission deadline. Call (864)-855-7908 to schedule an appointment.
2. Staff will review the application for "completeness". If the application is deemed incomplete, staff will notify the applicant and request that the application be revised and resubmitted to address incompleteness. In this event, the item will be postponed to a subsequent regularly scheduled planning commission meeting. A complete application includes: application filled out, payment for the annexation fee (\$250.00), payment for the rezoning fee (\$200.00 - if applicable), (2) copies of a current survey for the property (sized 8.5" x 11"), and the legal description of the property.
3. **A completed application is required for each separate parcel.**
4. **Public Notice Requirements.** Annexation applications require (1) Planning Commission and (2) City Council public hearings. It is the applicants responsibility to post the required public notice signs on the subject property(s) at least 15 days prior to the scheduled public hearings. See Section 4.1.4. Public Notice in the Unified Development Ordinance (UDO) for more information.
5. **Please read carefully:** The applicant and property owner affirm that all information submitted with this application; including any/all supplemental information is true and correct to the best of their knowledge and they have provided full disclosure of the relevant facts.

In addition, the applicant affirms that the applicant or someone acting on the applicant's behalf has made a reasonable effort to determine whether a deed or other document places one or more restrictions on the property that preclude or impede the intended use and has found no record of such a restriction. If the planning office by separate inquiry determines that such a restriction exists, it shall notify the applicant. If the applicant does not withdraw or modify the application in a timely manner, or act to have the restriction terminated or waived, then the planning office will indicate in its report to the planning commission that granting the requested change would not likely result in the benefit the applicant seeks.

Furthermore, my signature (applicant) indicates that I understand and consent that this matter will appear before the Planning Commission for consideration and that any recommendation, for approval or denial, by the Planning Commission will be presented to the City Council.



 5/18/26

APPLICANT SIGNATURE
 DATE

6. *Pursuant to S.C. Code Ann. § 6-29-1145, I hereby attest that the tract or parcel of land subject to this application IS NOT restricted by any recorded covenant that is contrary to, conflicts with, or prohibits the requested activity.
 Initial: DWO

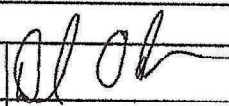
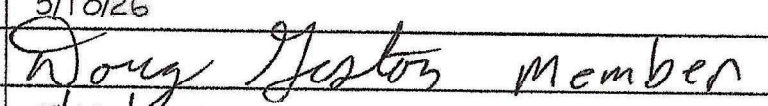
*Signatures	
Applicant	
Date	5/18/26
Property Owner/Authorized Agent	 member
Date	5/19/26



LIBERTAS ACADEMY

W1-B

- Notes:
- Area by coordinate geometry.
 - Survey does not certify file or ownership.
 - This plat was prepared without the benefit of a title search which may reveal additional conveyances, easements, rights-of-way, building restrictions, zoning, etc.
 - All property ownership information has been taken from current tax records.
 - Property is subject to easements, etc. of record.
 - Underground utilities have not been located.
 - Overhead utility lines have not been shown as part of this survey.
 - See town/city/county listed in the title block for all zoning information.
 - The RW for SC Highway 153, Rolling Hills Circle and a portion of Latham Road are of variable width. See SCDOT Plans for Project ID #39309 pages 9, 10, 11, 20 and 21. The RW for the remaining portion of Latham Road has not been determined as a part of this survey.
 - The Right of Way (RW) for Norfolk Southern Railroad is shown as 100' from the centerline, 200' total in PB 19 Pg 13, PB 435 Pg 8B, PB 623 Pg 95 and Page 9 of the SCDOT Highway Plans for Project ID #39309. RW monuments were found that match this stated RW.
 - GPS Data: (1) Positional accuracy: 0.015 M (0.05') (2) Type of GPS field procedure: SCORS Network RTK (3) Datum/EPOCH: NAD 83/2011 (4) Published/Field-control user SCORS System: (7) Geoid model: Geoid18 (8) Combined grid factor(s): 0.9999548806325 (9) Units: International Foot
 - DB 825 Pg 42 calls for the southern line of this parcel to run "along the Norfolk Southern Railroad right of way," however, the monument lines in that area cross over into the Norfolk Southern Railroad right of way (see note 9 for RW information). The hatched area shown hereon contains 0.41 acres and represents the portion of DB 825 Pg 42 (see also PB 491 Pg 07) that overlaps the Norfolk Southern Railroad. The ownership of this area is not clear. Said area should not be used until this issue is resolved. Point A shown hereon is the northeastern-most point of this 0.41 acre area where the Railroad RW crosses the property lines in DV 825 Pg 42. The total area of the surveyed property shown hereon is 13.80 acres. The area without this 0.41 acre area is 13.39 acres.
 - The RW areas for SC Highway 153, Rolling Hills Circle and the portion of Latham Road near the roundabout shown in SCDOT Plans for Project ID #39309 pages 9, 10, 11, 20 and 21 still appear to be under the ownership of Latham Road LLC in DB 825 Pg 42. No deed has been found conveying this property out of this stated ownership to the SCDOT or any other entity.

Preliminary Plat - Not for Recordation, Conveyance or Sales

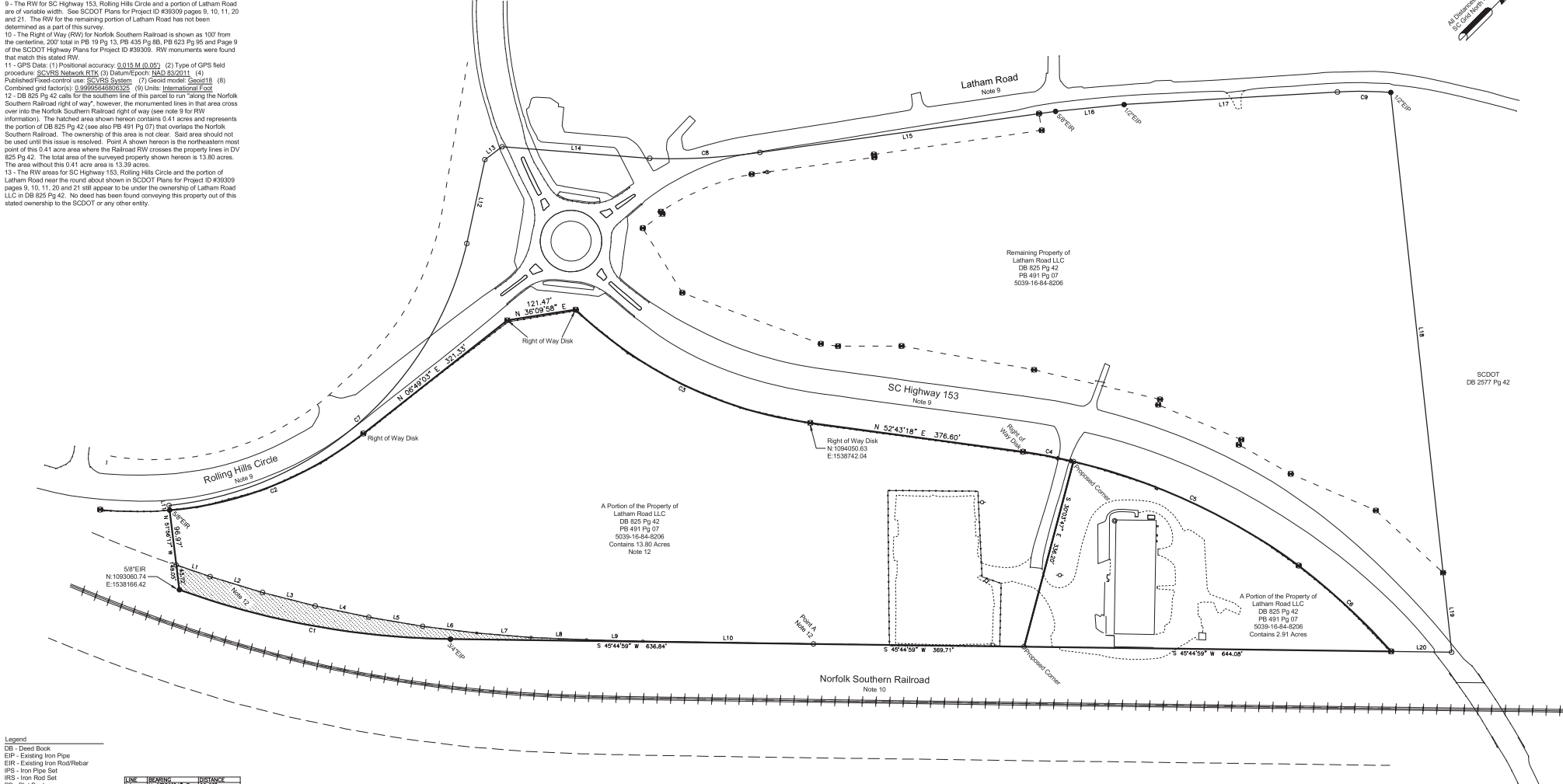

Legend

- DB - Deed Book
- EIP - Existing Iron Pipe
- EIR - Existing Iron Rod/Rebar
- IPS - Iron Pipe Set
- IRS - Iron Rod Set
- PB - Plat Book
- RW - Right of Way
- SR - State Road
- TL - Total Length
- As Noted
- EIR/EIP (not held)
- Unmarked Point
- ▲ As Noted
- As Noted
- Utility Pole
- Utility Pedestal
- Well
- Water Meter
- Man Hole
- Fire Hydrant
- Clean Out
- Right of Way Disc

LINE	BEARING	DISTANCE
L1	N 103°09'07.74"	108.00
L2	N 103°09'07.74"	108.00
L3	N 103°09'07.74"	108.00
L4	N 103°09'07.74"	108.00
L5	N 103°09'07.74"	108.00
L6	N 103°09'07.74"	108.00
L7	N 103°09'07.74"	108.00
L8	N 103°09'07.74"	108.00
L9	N 103°09'07.74"	108.00
L10	N 103°09'07.74"	108.00
L11	N 103°09'07.74"	108.00
L12	N 103°09'07.74"	108.00
L13	N 103°09'07.74"	108.00
L14	N 103°09'07.74"	108.00
L15	N 103°09'07.74"	108.00
L16	N 103°09'07.74"	108.00
L17	N 103°09'07.74"	108.00
L18	N 103°09'07.74"	108.00
L19	N 103°09'07.74"	108.00
L20	N 103°09'07.74"	108.00

CHORD	RADIUS	ARC LENGTH	CHORD LENGTH	CHORD BEARING	BETA ANGLE
C1	1456.13	146.77	146.52	S 35°19'07.00"	N 99°59'52.99"
C2	1755.50	176.64	176.37	S 35°19'07.00"	N 99°59'52.99"
C3	2054.87	207.51	207.10	S 35°19'07.00"	N 99°59'52.99"
C4	2354.24	238.38	237.87	S 35°19'07.00"	N 99°59'52.99"
C5	2653.61	269.25	268.64	S 35°19'07.00"	N 99°59'52.99"
C6	2952.98	300.12	299.41	S 35°19'07.00"	N 99°59'52.99"
C7	3252.35	330.99	330.28	S 35°19'07.00"	N 99°59'52.99"
C8	3551.72	361.86	361.15	S 35°19'07.00"	N 99°59'52.99"
C9	3851.09	392.73	392.02	S 35°19'07.00"	N 99°59'52.99"
C10	4150.46	423.60	422.89	S 35°19'07.00"	N 99°59'52.99"
C11	4449.83	454.47	453.76	S 35°19'07.00"	N 99°59'52.99"
C12	4749.20	485.34	484.63	S 35°19'07.00"	N 99°59'52.99"
C13	5048.57	516.21	515.50	S 35°19'07.00"	N 99°59'52.99"
C14	5347.94	547.08	546.37	S 35°19'07.00"	N 99°59'52.99"
C15	5647.31	577.95	577.24	S 35°19'07.00"	N 99°59'52.99"
C16	5946.68	608.82	608.11	S 35°19'07.00"	N 99°59'52.99"
C17	6246.05	639.69	638.98	S 35°19'07.00"	N 99°59'52.99"
C18	6545.42	670.56	669.85	S 35°19'07.00"	N 99°59'52.99"
C19	6844.79	701.43	700.72	S 35°19'07.00"	N 99°59'52.99"
C20	7144.16	732.30	731.59	S 35°19'07.00"	N 99°59'52.99"
C21	7443.53	763.17	762.46	S 35°19'07.00"	N 99°59'52.99"
C22	7742.90	794.04	793.33	S 35°19'07.00"	N 99°59'52.99"
C23	8042.27	824.91	824.20	S 35°19'07.00"	N 99°59'52.99"
C24	8341.64	855.78	855.07	S 35°19'07.00"	N 99°59'52.99"
C25	8641.01	886.65	885.94	S 35°19'07.00"	N 99°59'52.99"
C26	8940.38	917.52	916.81	S 35°19'07.00"	N 99°59'52.99"
C27	9239.75	948.39	947.68	S 35°19'07.00"	N 99°59'52.99"
C28	9539.12	979.26	978.55	S 35°19'07.00"	N 99°59'52.99"
C29	9838.49	1010.13	1009.42	S 35°19'07.00"	N 99°59'52.99"
C30	10137.86	1041.00	1040.29	S 35°19'07.00"	N 99°59'52.99"
C31	10437.23	1071.87	1071.16	S 35°19'07.00"	N 99°59'52.99"
C32	10736.60	1102.74	1102.03	S 35°19'07.00"	N 99°59'52.99"
C33	11035.97	1133.61	1132.90	S 35°19'07.00"	N 99°59'52.99"
C34	11335.34	1164.48	1163.77	S 35°19'07.00"	N 99°59'52.99"
C35	11634.71	1195.35	1194.64	S 35°19'07.00"	N 99°59'52.99"
C36	11934.08	1226.22	1225.51	S 35°19'07.00"	N 99°59'52.99"
C37	12233.45	1257.09	1256.38	S 35°19'07.00"	N 99°59'52.99"
C38	12532.82	1287.96	1287.25	S 35°19'07.00"	N 99°59'52.99"
C39	12832.19	1318.83	1318.12	S 35°19'07.00"	N 99°59'52.99"
C40	13131.56	1349.70	1348.99	S 35°19'07.00"	N 99°59'52.99"
C41	13430.93	1380.57	1379.86	S 35°19'07.00"	N 99°59'52.99"
C42	13730.30	1411.44	1410.73	S 35°19'07.00"	N 99°59'52.99"
C43	14029.67	1442.31	1441.60	S 35°19'07.00"	N 99°59'52.99"
C44	14329.04	1473.18	1472.47	S 35°19'07.00"	N 99°59'52.99"
C45	14628.41	1504.05	1503.34	S 35°19'07.00"	N 99°59'52.99"
C46	14927.78	1534.92	1534.21	S 35°19'07.00"	N 99°59'52.99"
C47	15227.15	1565.79	1565.08	S 35°19'07.00"	N 99°59'52.99"
C48	15526.52	1596.66	1595.95	S 35°19'07.00"	N 99°59'52.99"
C49	15825.89	1627.53	1626.82	S 35°19'07.00"	N 99°59'52.99"
C50	16125.26	1658.40	1657.69	S 35°19'07.00"	N 99°59'52.99"
C51	16424.63	1689.27	1688.56	S 35°19'07.00"	N 99°59'52.99"
C52	16724.00	1720.14	1719.43	S 35°19'07.00"	N 99°59'52.99"
C53	17023.37	1751.01	1750.30	S 35°19'07.00"	N 99°59'52.99"
C54	17322.74	1781.88	1781.17	S 35°19'07.00"	N 99°59'52.99"
C55	17622.11	1812.75	1812.04	S 35°19'07.00"	N 99°59'52.99"
C56	17921.48	1843.62	1842.91	S 35°19'07.00"	N 99°59'52.99"
C57	18220.85	1874.49	1873.78	S 35°19'07.00"	N 99°59'52.99"
C58	18520.22	1905.36	1904.65	S 35°19'07.00"	N 99°59'52.99"
C59	18819.59	1936.23	1935.52	S 35°19'07.00"	N 99°59'52.99"
C60	19118.96	1967.10	1966.39	S 35°19'07.00"	N 99°59'52.99"
C61	19418.33	1997.97	1997.26	S 35°19'07.00"	N 99°59'52.99"
C62	19717.70	2028.84	2028.13	S 35°19'07.00"	N 99°59'52.99"
C63	20017.07	2059.71	2059.00	S 35°19'07.00"	N 99°59'52.99"
C64	20316.44	2090.58	2089.87	S 35°19'07.00"	N 99°59'52.99"
C65	20615.81	2121.45	2120.74	S 35°19'07.00"	N 99°59'52.99"
C66	20915.18	2152.32	2151.61	S 35°19'07.00"	N 99°59'52.99"
C67	21214.55	2183.19	2182.48	S 35°19'07.00"	N 99°59'52.99"
C68	21513.92	2214.06	2213.35	S 35°19'07.00"	N 99°59'52.99"
C69	21813.29	2244.93	2244.22	S 35°19'07.00"	N 99°59'52.99"
C70	22112.66	2275.80	2275.09	S 35°19'07.00"	N 99°59'52.99"
C71	22412.03	2306.67	2305.96	S 35°19'07.00"	N 99°59'52.99"
C72	22711.40	2337.54	2336.83	S 35°19'07.00"	N 99°59'52.99"
C73	23010.77	2368.41	2367.70	S 35°19'07.00"	N 99°59'52.99"
C74	23310.14	2399.28	2398.57	S 35°19'07.00"	N 99°59'52.99"
C75	23609.51	2430.15	2429.44	S 35°19'07.00"	N 99°59'52.99"
C76	23908.88	2461.02	2460.31	S 35°19'07.00"	N 99°59'52.99"
C77	24208.25	2491.89	2491.18	S 35°19'07.00"	N 99°59'52.99"
C78	24507.62	2522.76	2522.05	S 35°19'07.00"	N 99°59'52.99"
C79	24806.99	2553.63	2552.92	S 35°19'07.00"	N 99°59'52.99"
C80	25106.36	2584.50	2583.79	S 35°19'07.00"	N 99°59'52.99"
C81	25405.73	2615.37	2614.66	S 35°19'07.00"	N 99°59'52.99"
C82	25705.10	2646.24	2645.53	S 35°19'07.00"	N 99°59'52.99"
C83	26004.47	2677.11	2676.40	S 35°19'07.00"	N 99°59'52.99"
C84	26303.84	2707.98	2707.27	S 35°19'07.00"	N 99°59'52.99"
C85	26603.21	2738.85	2738.14	S 35°19'07.00"	N 99°59'52.99"
C86	26902.58	2769.72	2769.01	S 35°19'07.00"	N 99°59'52.99"
C87	27201.95	2800.59	2799.88	S 35°19'07.00"	N 99°59'52.99"
C88	27501.32	2831.46	2830.75	S 35°19'07.00"	N 99°59'52.99"
C89	27800.69	2862.33	2861.62	S 35°19'07.00"	N 99°59'52.99"
C90	28100.06	2893.20	2892.49	S 35°19'07.00"	N 99°59'52.99"
C91	28400.43	2924.07	2923.36	S 35°19'07.00"	N 99°59'52.99"
C92	28700.80	2954.94	2954.23	S 35°19'07.00"	N 99°59'52.99"
C93	29000.17	2985.81	2985.10	S 35°19'07.00"	N 99°59'52.99"
C94	29300.54	3016.68	3015.97	S 35°19'07.00"	N 99°59'52.99"
C95	29600.91	3047.55	3046.84	S 35°19'07.00"	N 99°59'52.99"
C96	29900.28	3078.42	3077.71	S 35°19'07.00"	N 99°59'52.99"
C97	30200.65	3109.29	3108.58	S 35°19'07.00"	N 99°59'52.99"
C98	30500.02	3140.16	3139.45	S 35°19'07.00"	N 99°59'52.99"
C99	30800.39	3171.03	3170.34	S 35°19'07.00"	N 99°59'52.99"
C100	31100.76	3201.90	3201.19	S 35°19'07.00"	N 99°59'52.99"

I hereby state that to the best of my knowledge, information and belief, the survey shown hereon was made in accordance with the requirements of the Minimum Standards Manual for the Practice of Land Surveying in South Carolina, and meets or exceeds the requirements for a Class A Survey as specified therein.

Witness my original signature, registration number and seal this 18th day of May, 2023

This is an Unsigned Electronic Plat Copy/Site Plan
Preliminary Plat - Not for Recordation, Conveyance or Sales

John W. Terry II - SCPLS # 22761



Survey For: Tutelage School Site			
Survey Of: Proposed Division on SC Highway 153 and Rolling Hills Circle			
State: South Carolina	County: Pickens		
DB 825 Pg 42	PIN: 5039-16-84-8206	Scale: 1" = 80'	
PB 491 Pg 07		Date: 5/7/2023	
Owner(s): Latham Road LLC		Drawing #: 2763	



to a point; thence continuing S56-19-03W 485.91 feet (chord distance of 483.66 feet) to a point, being the point of beginning."

This being the same property conveyed to Douglas T. Gaston, J. Bruce Gaston, and James O. Richey by deed of Michael Sabee dated December 31, 2003, and recorded on January 8, 2004, in Deed Book 785 at Page 269, Office of Register of Deeds for Pickens County, South Carolina.

This conveyance is subject to any and all rights of way for roads, utilities and other easements, restrictions and/or zoning ordinances which may appear on record and/or from an inspection of the premises, and further subject to all rights of way to Norfolk Southern Railroad (f/k/a Southern Railway Company), and rights of way for South Highway 153 and its expansion.

Grantee's Address: 403 East First Ave., Easley, SC 29640

TMS No.: 5039-16-84-8206

TOGETHER with all and singular the rights, members, hereditaments and appurtenances to said premises belonging or in any wise incident or appertaining;

TO HAVE AND TO HOLD all and singular the premises before mentioned unto the Grantee, and the Grantee's heirs and assigns forever. And the Grantor do hereby bind the grantor and the grantor's heirs or successors, executors and administrators to warrant and forever defend all and singular said premises unto the Grantee and the Grantee's heirs or successors and against every person whomsoever lawfully claiming or to claim the same or any part thereof.

Any reference to this instrument to the singular shall include the plural, and vice versa. Any reference to one gender shall include the others, including the neuter. Such words of inheritance shall be applicable as are required by the gender of the Grantee.

WITNESS the Grantor's hands and seals this the 16th day of June, 2004.

SIGNED, SEALED AND DELIVERED

in the presence of:

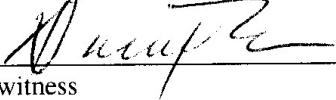
witness

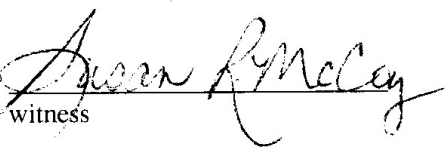
witness

 (SEAL)
DOUGLAS T. GASTON

 (SEAL)
J. BRUCE GASTON

 (SEAL)
JAMES O. RICHEY

State of South Carolina)
)
County of Pickens)

PROBATE

PERSONALLY APPEARED BEFORE ME the undersigned witness and made oath that (s)he saw the within-named Douglas T. Gaston, Jr., J. Bruce Gaston, and James O. Richey sign, seal, and, as their act and deed, deliver the within-written Title to Real Estate, and that (s)he, with the other witness subscribed above, witnessed the execution thereof.

Susan R. Moley
Witness

SWORN to before me this 16th day of June, 2004.

[Signature] (SEAL)
Notary Public for South Carolina

My Commission Expires: 3-1-2006

EXEMPTIONS**Exempted are deeds:**

- (1) transferring realty to the federal government;
- (2) transferring realty to the State, its agencies and departments, and its political subdivision, including school districts;
- (3) otherwise exempted under the laws and Constitution of the United States or the laws or Constitution of South Carolina;
- (4) transferring realty whereby no gain or loss is recognized by reason of Section 1041 of the Internal Revenue Code as defined in Section 12-8-40(A) of the South Carolina Code of Laws. This exemption will exempt transfers to a spouse and most transfers that are the result of a divorce;
- (5) transferring realty from an agent to the agent's principal in which the realty was purchased with the funds of the principal;
- (6) transferring an individual grave space at a cemetery owned by a cemetery company licensed under Chapter 55 of Title 30 of the South Carolina Code of Laws;
- (7) transferring realty to a member of the family or to a family trust or to a family partnership. "Family" means spouse, parents, sisters, brothers, grandparents, grandchildren and lineal descendants. A "family trust" is a trust whose beneficiaries are all members of the family of the transferor. A "family partnership" is a partnership whose partners are all members of the family of the transferor;
- (8) transferring realty to a legal heir or devisee;
- (9) that constitute a contract for the sale of timber to be cut;
- (10) transferring realty from an individual to a partnership, limited liability company, or corporation upon the formation of the entity if the individual is transferring the realty in order to become a partner, member, or shareholder in the entity. All other transfers of realty to or from the partnership, limited liability company, or corporation, not otherwise exempt, are subject to the fee.
- (11) transferring realty in a statutory merger or consolidation from a constituent corporation to the continuing or new corporation;
- (12) transferring realty between a parent corporation and its subsidiary corporation, provided that no consideration of any kind is paid or to be paid for the transfer;
- (13) transferring realty to a nonprofit corporation organized and operated exclusively for either a religious, scientific, charitable, or educational purpose, and provided no consideration of any kind is paid or to be paid for the transfer;
- (14) that constitute a corrective deed or a quitclaim deed used to confirm title already vested in the grantee, provided no consideration of any kind is paid or to be paid for the corrective or quitclaim deed; or,
- (15) transferring realty from an individual to a partnership or limited liability company of which the individual is a partner or a member, provided that the transfer is subject to the fee to the extent that the transfer is a transfer of any undivided interest in the realty to partners or members other than the transferor. The determination as to the portion of the realty's value upon which the fee must be paid must be based on the percentage interest in the partnership or limited liability company of the partners or members other than the

TRAFFIC IMPACT STUDY

Libertas Academy Charter School Easley, South Carolina

JUNE 7, 2026

IMPACT DESIGNS, INC.

Prepared by: Allen J. Reid, PE

TRAFFIC IMPACT STUDY

Libertas Academy Charter School

EASLEY, SOUTH CAROLINA



REPORT PREPARED FOR:

Hubrich Contracting, Inc.
4321 Medical Park Drive, Suite 100
Durham, NC 27704

REPORT PREPARED BY

Impact Designs Inc.
172 Williamson Road, Unit 3728
Mooresville, NC 28117
allen@impactdesignsinc.com

Table of Contents

EXECUTIVE SUMMARY	iii
1. INTRODUCTION	1
1.1. Project Summary	1
1.2. Existing Roadway Conditions.....	2
1.3. Driveway Locations	2
2. TRAFFIC VOLUME DEVELOPMENT.....	6
2.1. Existing Traffic Volumes.....	6
2.2. Projected Traffic Volumes	6
2.3. Proposed Development Traffic Volumes	6
2.4. Future Build Traffic Volumes	7
3. TRAFFIC IMPACT ANALYSIS	13
3.1. Turn Lane Analysis	13
3.2. Intersection LOS Analysis.....	13
4. SUMMARY OF FINDINGS	17

Tables

Table 1 – Study Area Summary 2

Table 2 – Project Trip Generation..... 6

Table 3 – *HCM 6th Edition* LOS Criteria for Signalized & Unsignalized Intersections 13

Table 4 – Intersection Capacity Analysis Results..... 14

Figures

Figure 1 – Project Location..... 3

Figure 2 – Conceptual Site Plan..... 4

Figure 3 – Existing Lane Configuration 5

Figure 4 – Existing (2026) Traffic Volumes..... 8

Figure 5 – No-Build (2028) Traffic Volumes..... 9

Figure 6 – Trip Distribution..... 10

Figure 7 – Trip Assignments..... 11

Figure 8 – Build (2028) Traffic Volumes 12

Figure 9 – Recommended Lane Configuration..... 16

Appendices

- A) Traffic Count Data
- B) Turn Lane Analysis
- C) Synchro Analysis Reports
- D) SimTraffic Analysis Reports
- E) Existing Signal Plans and Timings

EXECUTIVE SUMMARY

A traffic impact study was conducted for the proposed Libertas Academy Charter School development in accordance with SCDOT guidelines. The proposed development is located south of SC 153, east of Rolling Hills Circle in Easley, SC. The development is expected to consist of a K-8 charter school with a capacity of 1,000 students and 70 faculty members which is expected to be completed by 2028. Direct access to Libertas Academy Charter School development site is proposed to be provided via a full movement access for drop-off and pick-up on Rolling Hills Circle. A secondary shared access with the rental business to the east of the site is proposed to be utilized for the faculty and visitor parking lot.

The study was determined through coordination with SCDOT and consists of the following intersections:

- US 123 and Prince Perry Road / Rock Springs Road
- US 123 and Town Center Way
- Town Center Way and Rolling Hills Circle
- SC 153 and Rolling Hills Circle / Latham Road
- SC 153 and US 123 Westbound Ramps
- SC 153 and Shared Access B
- Rolling Hills Circle and Access A

For the purpose of this analysis, the study intersections listed above were analyzed under the following scenarios:

- Existing (2026) Conditions
- No-Build (2028) Conditions
- Build (2028) Conditions

Traffic operations during the AM, SCH and PM peak hours were modeled for each scenario. The results of each scenario were compared to determine impacts from background traffic growth and the proposed development.

Recommendations:

- Construct a northbound right turn lane on Rolling Hills Circle at Access A with 150 feet of storage and appropriate taper.
- Construct dual westbound left turn lanes on US 123 at Prince Perry Road / Rock Springs Road. The additional left turn lane have at least 250 feet of storage.
- Widen Rock Springs Road for an additional southbound receiving lane extending to Dayton School Road.
- Modify the signal plan at US 123 and Prince Perry Road / Rock Springs Road to accommodate the improvements.
- Install protected/permitted left turn phasing for the westbound approach of Rolling Hills Circle at Town Center Way.

1. INTRODUCTION

The purpose of this report is to summarize the traffic impact study that was completed for the Libertas Academy Charter School development in Easley, South Carolina. The study was developed in accordance with SCDOT guidelines. This report summarizes the procedures and findings of the traffic impact study.

1.1. Project Summary

The proposed development is located south of SC 153, east of rolling Hills Circle in Easley, SC. The development is expected to consist of a K-8 charter school with a capacity of 1,000 students and 70 faculty members which is expected to be completed by 2028. This traffic impact study analyzes the effects of the additional traffic associated with the proposed development during the weekday AM (7:00 AM - 9:00 AM), the school PM (2:00 – 4:00 PM), and the weekday PM (4:00 PM - 6:00 PM) peak periods. The study area for the purpose of the analysis includes:

- US 123 and Prince Perry Road / Rock Springs Road
- US 123 and Town Center Way
- Town Center Way and Rolling Hills Circle
- SC 153 and Rolling Hills Circle / Latham Road
- SC 153 and US 123 Westbound Ramps
- SC 153 and Shared Access B
- Rolling Hills Circle and Access A

Refer to Figures 1 and 2 for the site location and the conceptual site plan.

For the purpose of this analysis, the study intersections listed above were analyzed under the following scenarios:

- Existing (2026) Conditions
- No-Build (2028) Conditions
- Build (2028) Conditions
- Build Improved (2028) Conditions

1.2. Existing Roadway Conditions

The primary roadways within the study area include US 123, SC 153, and Rolling Hills Circle. A summary of their existing characteristics is shown in Table 1.

Table 1 – Study Area Summary



Facility Name	Route #	Typical Cross Section	Posted Speed Limit	Maintained By	2025 AADT
US 123		4-lane divided	45 MPH	SCDOT	44,500
SC 153		2-lane undivided	45 MPH	SCDOT	10,200
Rolling Hills Circle	S-189	2-lane undivided	25/40 MPH	SCDOT	No Data

Refer to Figure 3 for an illustration of the existing geometry and traffic control at the study intersections.

1.3. Driveway Locations

Direct access to Libertas Academy Charter School development site is proposed to be provided via a full movement access for drop-off and pick-up on Rolling Hills Circle. A secondary shared access with the rental business to the east of the site is proposed to be utilized for the faculty and visitor parking lot.



LEGEND	
	Proposed Site Location
	Study Intersections

IMPACT Designs, Inc.		
<i>Libertas Charter School Easley, SC</i>		
Site Location Map		
Scale: Not to Scale	Figure	1

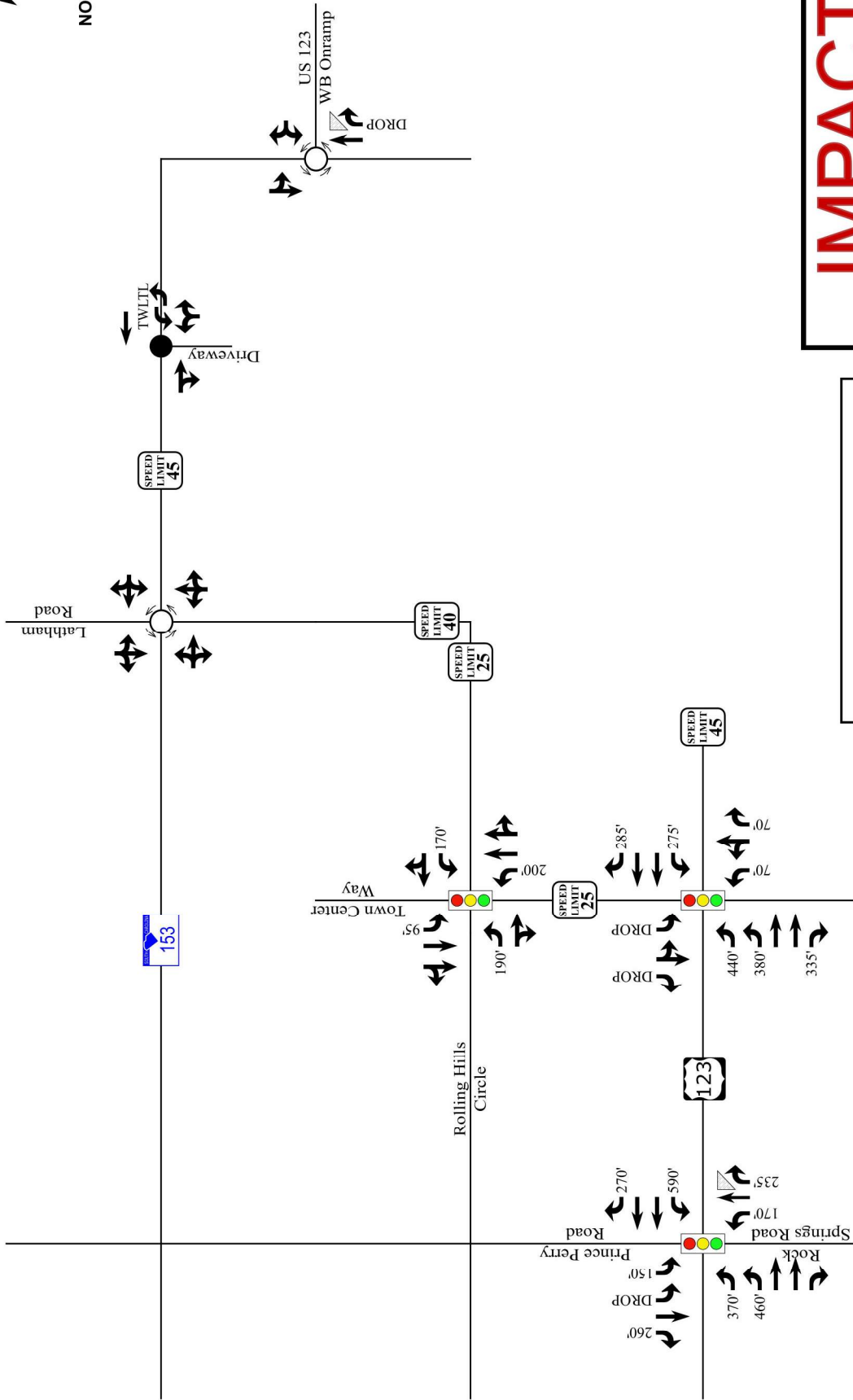

LEGEND

- Signalized Intersection (Traffic light symbol)
- Unsignalized Intersection (Black dot symbol)
- Existing Lane (Arrow symbol)
- Storage (in feet) (X symbol)
- Posted Speed Limit (Speed limit sign symbol)

IMPACT
Designs, Inc.

*Libertas Charter School
Easley, SC*

Existing Lane Configurations
and Traffic Control

Scale: Not to Scale	Figure	3
---------------------	--------	---

2. TRAFFIC VOLUME DEVELOPMENT

2.1. Existing Traffic Volumes

Existing turning movement counts were conducted in March 2026. The counts were collected during the AM (7:00 AM to 9:00 AM) peak period, the school PM (2:00 PM to 4:00 PM) peak period, and the PM (4:00 PM to 6:00 PM) peak period. The existing traffic volumes are illustrated in Figure 4. Refer to appendix A for a copy of the raw traffic counts.

2.2. Projected Traffic Volumes

Based on SCDOT Average Annual Daily Traffic (AADT) volumes, daily traffic volumes in the study area have increased steadily in recent years at an average rate of 4% per year. To reflect continued growth, a 4% annual growth rate was applied to the 2026 counts to develop the No-Build (2028) volumes. This growth rate was applied to account for background growth in the area. Refer to Figure 5 for an illustration of the No-Build (2028) traffic volumes at the study intersections.

2.3. Proposed Development Traffic Volumes

As mentioned previously, the development is expected to consist of a K-8 charter school with a capacity of 1,000 students and 70 faculty members. The school plans to operate three buses which were assumed to accommodate 120 students. At the request of SCDOT, the AM and SCH peak hour trip generation potential for the proposed development was estimated using the trip generation spreadsheet provided by SCDOT staff. The daily and PM peak hour trip generation was estimated utilizing methodology contained within the ITE’s *Trip Generation Manual*, 12th Edition, specifically the charter elementary school (ITE Code 536) data. Utilizing the SCDOT spreadsheet, and the ITE data for ITE Codes 536, site traffic volumes were generated for the weekday daily, the weekday AM peak hour, the weekday school peak hour (SCH), and the weekday PM peak hour. Refer to Appendix A for the trip generation spreadsheet methodology. Refer to Table 2 for a summary of the trip generation potential of the proposed development.

Table 2 – Project Trip Generation

Land Use	ITE Code	Size		Traffic Volume						
		Quantity	Unit	Daily	AM		SCH		PM	
					Enter	Exit	Enter	Exit	Enter	Exit
SCDOT School Trip Generation Worksheet		1,000	Students	-	577	507	373	443	-	-
Charter Elementary School	536			1,850	-	-	-	-	56	104
Total Primary Trips				1,850	577	507	373	443	56	104

Traffic associated with the proposed development was distributed and assigned to the roadway network based upon existing travel patterns. The trip distributions are summarized below:

- 30% to/from the west via US 123
- 20% to/from the east via US 123
- 25% to/from the south via Rock Springs Road
- 15% to/from the south via SC 153
- 5% to/from the north via SC 153
- 5% to/from the north via Latham Road

Refer to Figures 6 and 7 for the site trip distributions and assignments.

2.4. Future Build Traffic Volumes

The site generated traffic volumes were added to the No-Build (2028) traffic volumes to determine the Build (2028) volumes. The Build (2028) volumes are illustrated in Figure 8.

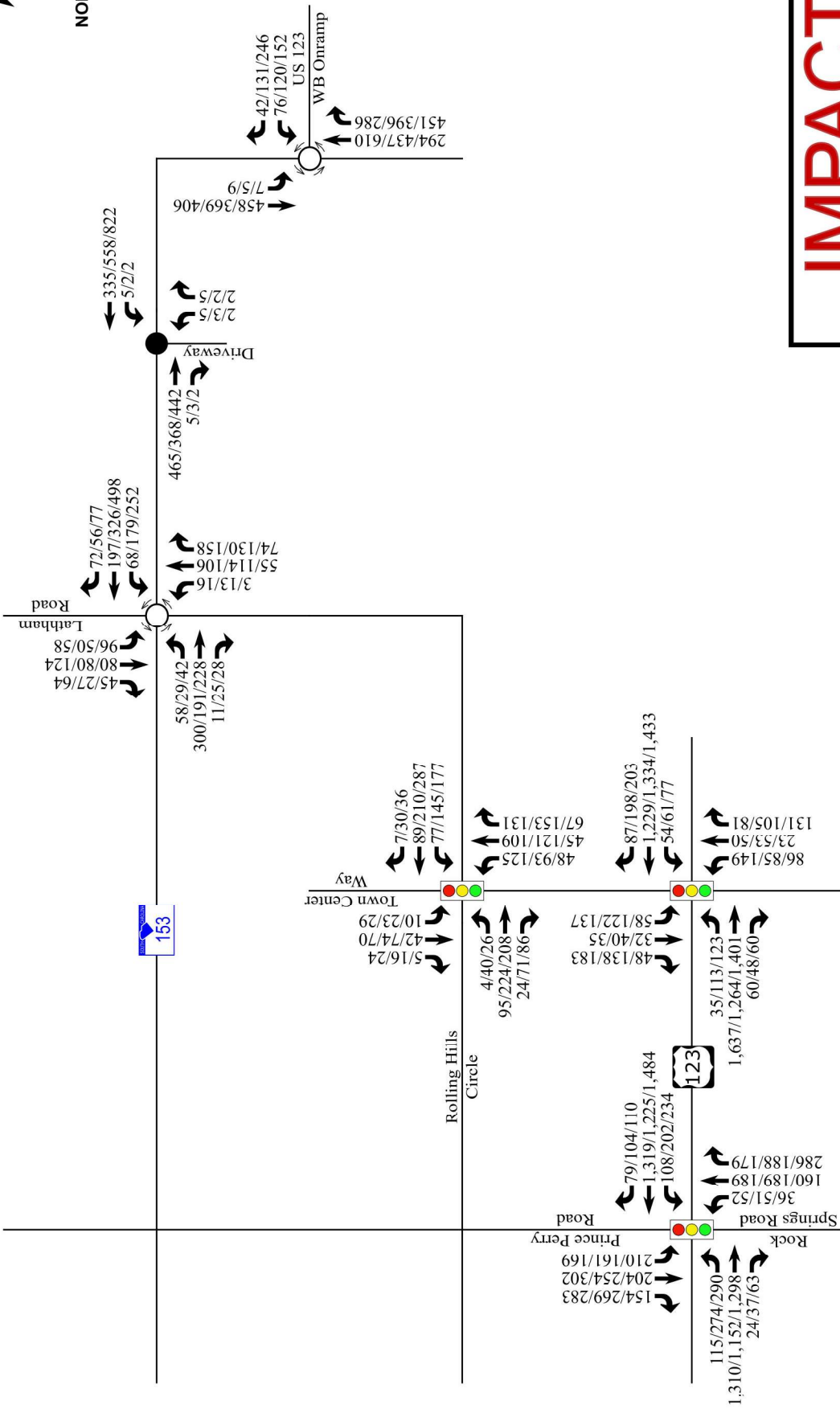

IMPACT
Designs, Inc.

*Libertas Charter School
Easley, SC*

Existing (2026)
Traffic Volumes

Scale: Not to Scale

Figure

4

LEGEND

- Signalized Intersection
- Unsignalized Intersection
- AM / PM Peak Hour Traffic

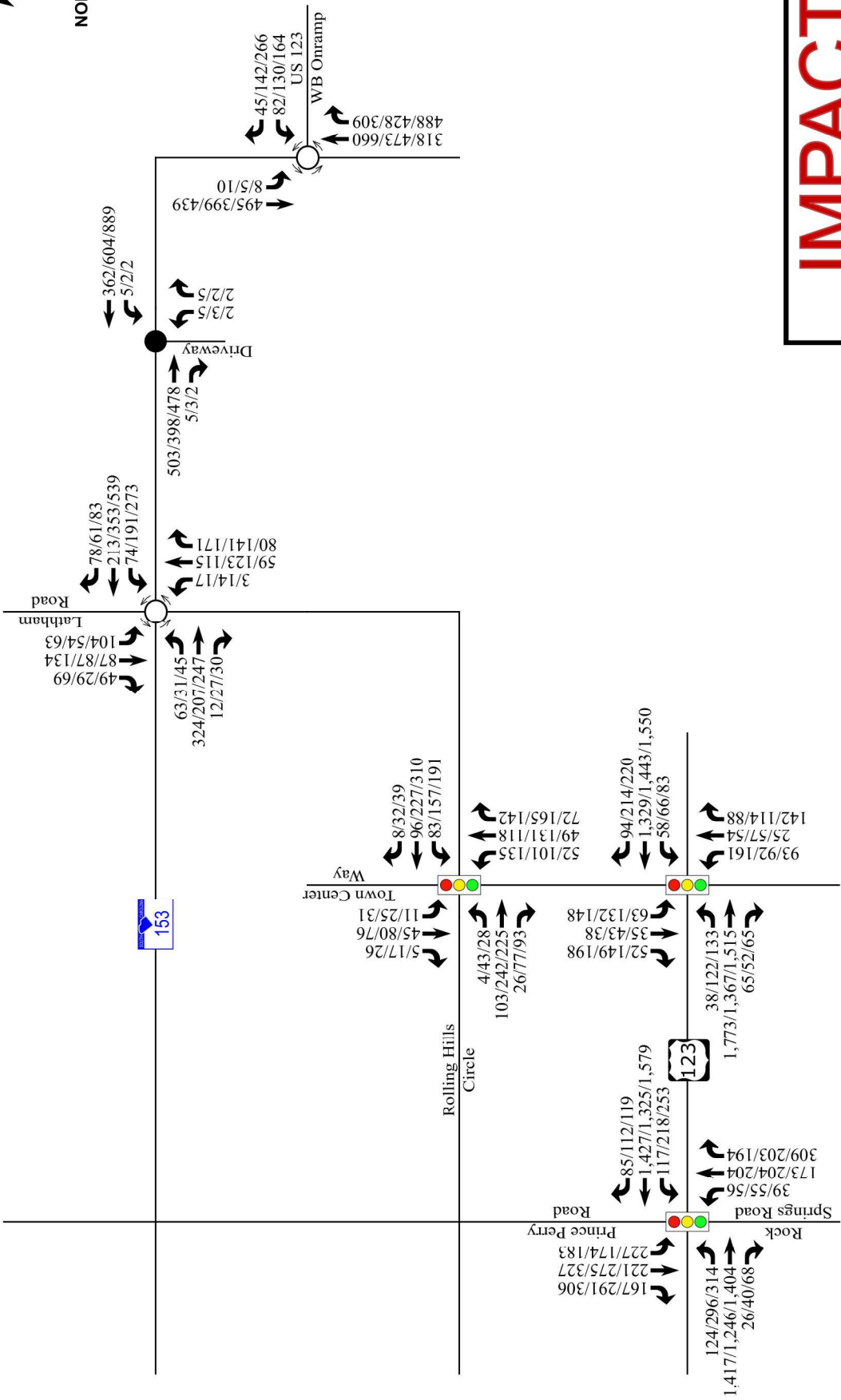

IMPACT
Designs, Inc.

*Libertas Charter School
Easley, SC*

No-Build (2028)
Traffic Volumes

Scale: Not to Scale

Figure

5

LEGEND

- Signalized Intersection
- Unsignalized Intersection
- X/Y → AM / PM Peak Hour Traffic

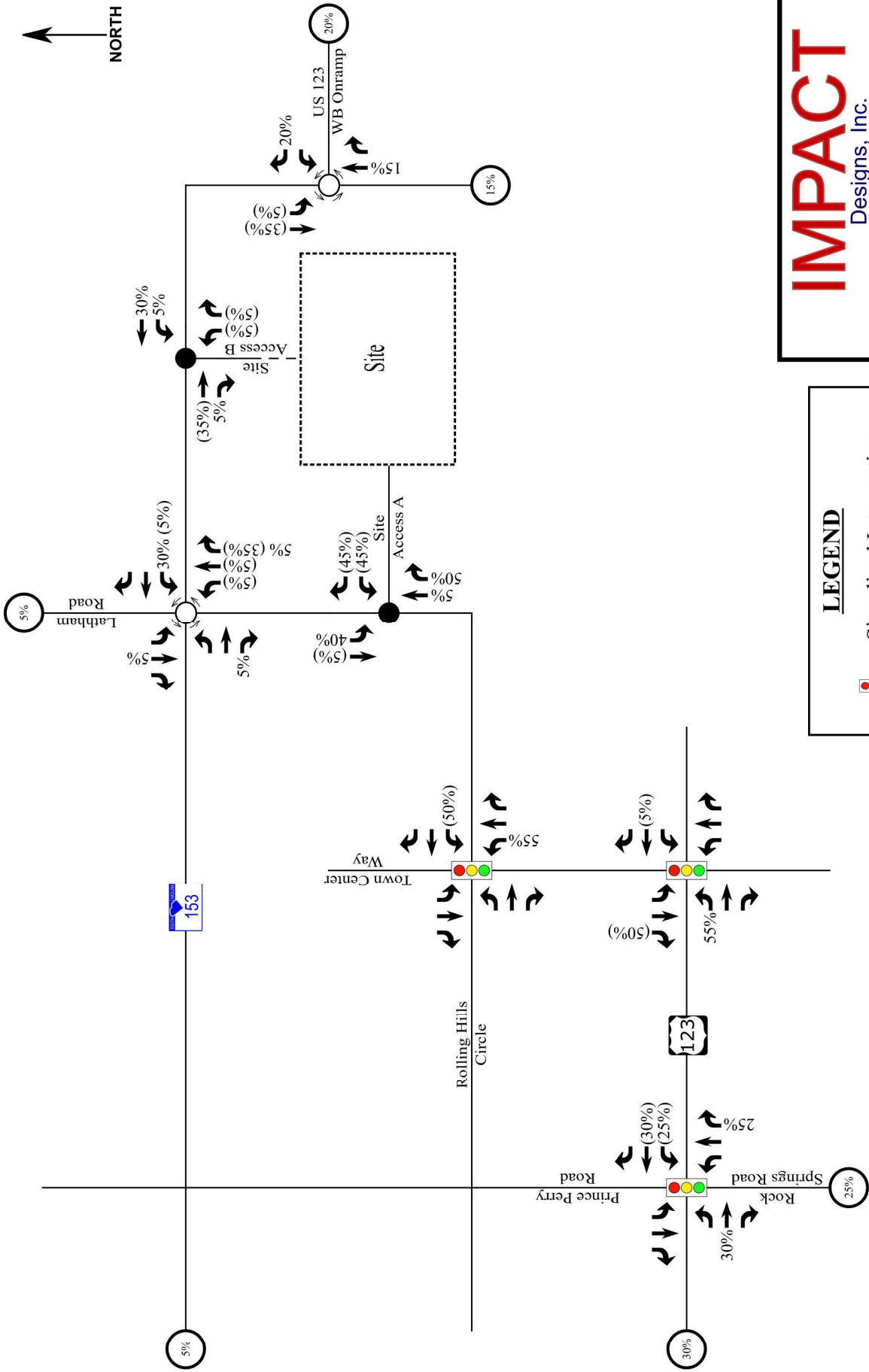

LEGEND

- Signalized Intersection
- Unsignalized Intersection
- Entering Trip Distribution (X%)
- Exiting Trip Distribution (Y%)
- Regional Trip Distribution

IMPACT
Designs, Inc.

*Libertas Charter School
Easley, SC*

Site Trip Distribution

Scale: Not to Scale

Figure 6

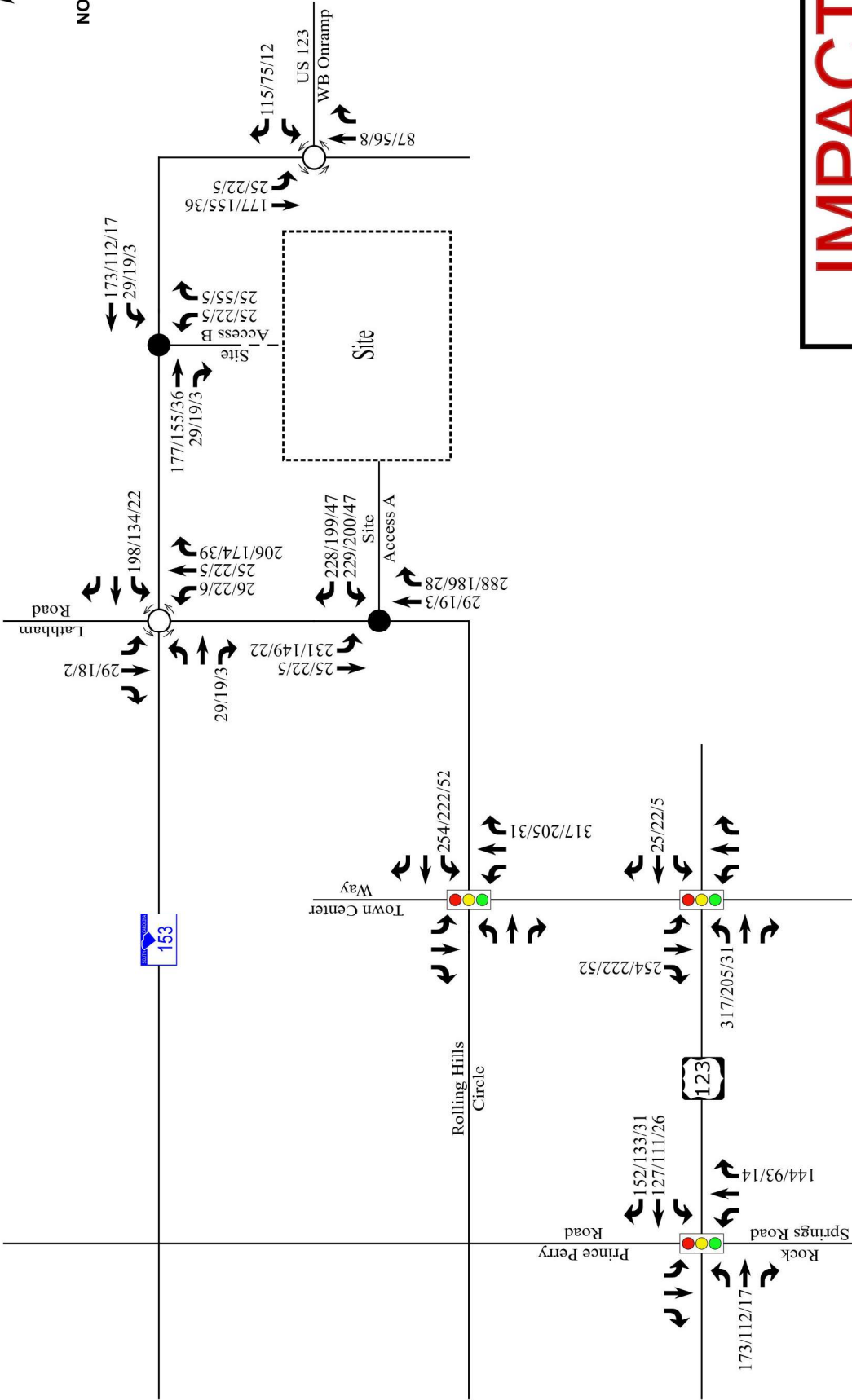
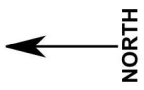

IMPACT
Designs, Inc.

*Libertas Charter School
Easley, SC*

Trip Assignments

Scale: Not to Scale

Figure

7

LEGEND

- Signalized Intersection
- Unsignalized Intersection
- AM / PM Peak Hour Traffic

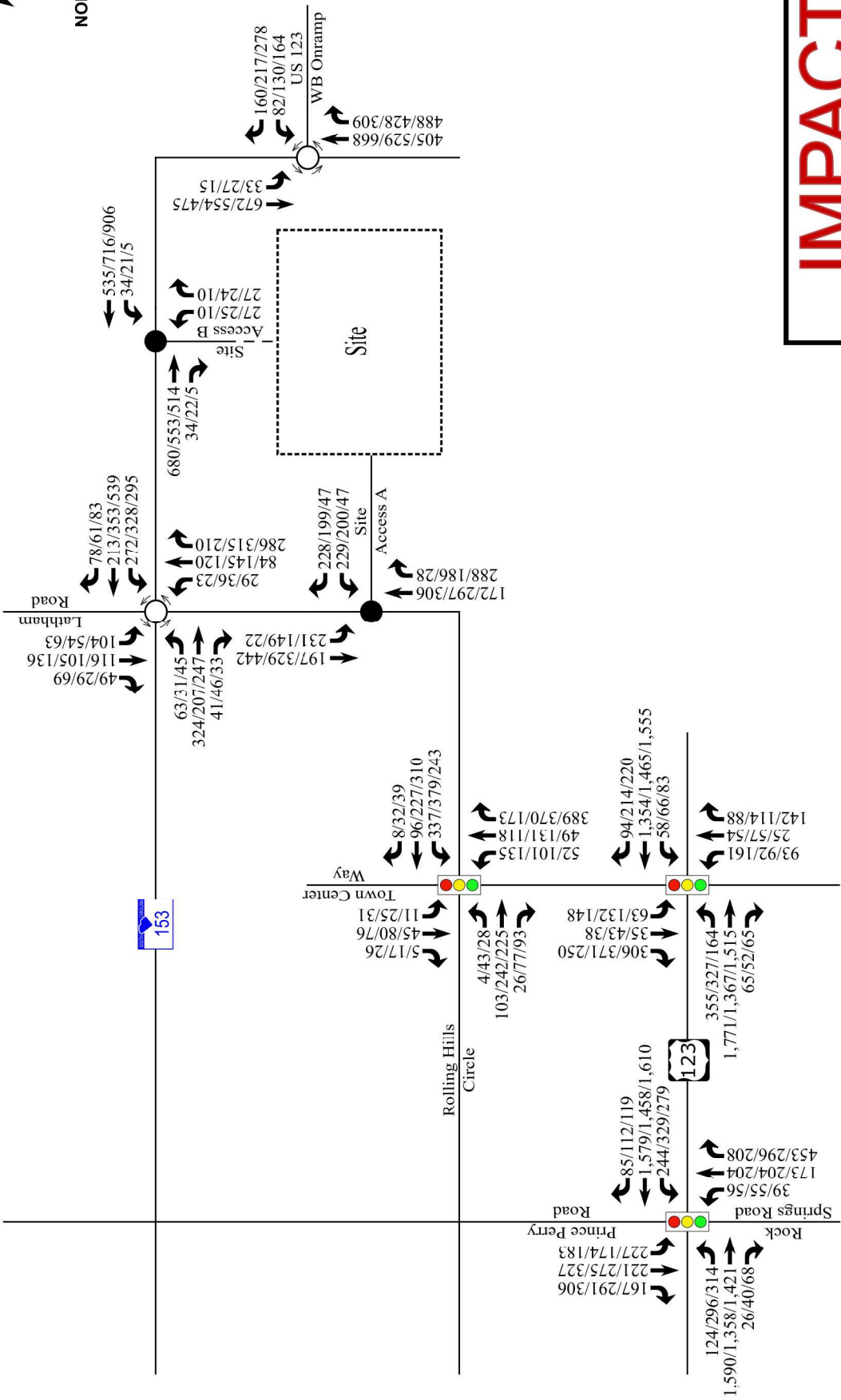

153

123

LEGEND

- Signalized Intersection
- Unsignalized Intersection
- X/Y → AM / PM Peak Hour Traffic

IMPACT
Designs, Inc.

*Libertas Charter School
Easley, SC*

Build (2028)
Traffic Volumes

Scale: Not to Scale

Figure 8

3. TRAFFIC IMPACT ANALYSIS

3.1. Turn Lane Analysis

A turn lane analysis was conducted at the site access utilizing the Build (2028) volumes. Based on these volumes, a southbound left turn lane and a northbound right turn lane are warranted on Rolling Hills Circle at Access A. However, Rolling Hills Circle has an existing two-way left turn lane (TWLTL) which could be utilized instead of installing a left turn lane. Additionally, a left turn lane is warranted on SC 153 at Shared Access B, but SC 153 also has an existing TWLTL which could be utilized instead.

Refer to Appendix B for the turn lane warrants with volumes graphed.

3.2. Intersection LOS Analysis

Using the existing, no-build, and build traffic volumes, intersection analyses were conducted for the study intersections under Existing (2026) conditions, No-Build (2028) conditions, Build (2028) conditions and Build Improved (2028) conditions. This analysis was conducted using the Transportation Research Board’s *Highway Capacity Manual (HCM 6th Edition)* methodologies of the *Synchro*, Version 12 software.

Intersection level of service (LOS) grades range from LOS A to LOS F, which are directly related to the level of control delay at the intersection and characterize the operational conditions of the intersection traffic flow. LOS A operations typically represent ideal, free-flow conditions where vehicles experience little to no delays, and LOS F operations typically represent poor, forced-flow (bumper-to-bumper) conditions with high vehicular delays, and are generally considered undesirable. Table 3 summarizes the *HCM 6th Edition* control delay thresholds associated with each LOS grade for signalized and unsignalized intersections.

Table 3 – HCM 6th Edition LOS Criteria for Signalized & Unsignalized Intersections

Signalized Intersections		Unsignalized Intersections	
LOS	Control Delay per Vehicle (seconds)	LOS	Control Delay per Vehicle (seconds)
A	≤ 10	A	≤ 10
B	> 10 and ≤ 20	B	> 10 and ≤ 15
C	> 20 and ≤ 35	C	> 15 and ≤ 25
D	> 35 and ≤ 55	D	> 25 and ≤ 35
E	> 55 and ≤ 80	E	> 35 and ≤ 50
F	> 85	F	> 50

The results of the capacity analysis for the study intersections are summarized in Table 4. Refer to Appendix C for the detailed capacity analysis reports and Appendix D for the queuing analysis results.

Table 4 – Intersection Capacity Analysis Results

Intersections	Approach	LOS (Delay in seconds per vehicle)											
		Existing (2026)			No-Build (2028)			Build (2028)			Build Improved (2028)		
		AM	SCH	PM	AM	SCH	PM	AM	SCH	PM	AM	SCH	PM
US 123 & Prince Perry Road/Rock Springs Road	EB	D (37.5)	D (42.7)	E (55.3)	D (42.4)	D (47.7)	E (66.7)	E (64.6)	E (56.2)	E (64.7)	D (48.4)	D (54.3)	D (50.2)
	WB	C (24.7)	C (28.2)	D (36.0)	C (28.4)	C (32.9)	D (45.3)	D (47.8)	E (65.0)	F (82.3)	D (40.8)	D (36.1)	D (49.4)
	NB	C (30.0)	D (37.0)	D (46.2)	C (30.9)	D (38.1)	D (45.7)	C (24.4)	C (31.8)	D (37.9)	C (23.8)	C (31.8)	D (41.0)
	SB	D (51.7)	D (45.3)	E (72.3)	D (53.3)	D (47.2)	F (80.9)	D (53.5)	D (47.3)	E (56.0)	D (54.5)	D (47.7)	E (71.0)
	Overall	C (33.8)	D (37.1)	D (49.7)	D (37.3)	D (41.1)	E (58.8)	D (51.3)	E (55.5)	E (67.8)	D (42.9)	D (43.7)	D (52.3)
US 123 & Town Center Way	EB	B (18.8)	C (34.2)	C (20.8)	C (24.3)	D (37.4)	C (23.2)	D (44.2)	D (40.9)	D (43.8)	C (33.9)	D (41.1)	D (40.9)
	WB	C (20.2)	C (27.8)	C (24.9)	C (22.0)	C (32.2)	C (28.2)	C (28.0)	D (45.5)	D (49.0)	C (32.8)	D (41.4)	D (49.0)
	NB	D (41.3)	D (41.6)	E (77.2)	D (43.6)	D (42.2)	F (80.4)	D (43.6)	D (42.2)	D (50.8)	D (42.7)	D (42.2)	D (50.8)
	SB	D (40.1)	D (38.6)	E (59.1)	D (40.8)	D (39.7)	E (61.8)	E (60.6)	D (42.7)	D (38.4)	D (52.0)	D (48.2)	D (44.2)
	Overall	C (21.7)	C (32.2)	C (30.1)	C (25.4)	D (35.6)	C (33.0)	D (40.1)	D (43.1)	D (46.0)	D (35.3)	D (42.2)	D (45.4)
Rolling Hills Circle & Town Center Way	EB	C (25.4)	C (22.6)	C (25.4)	C (25.7)	C (21.5)	C (23.7)	B (11.8)	B (13.0)	B (15.4)	C (28.3)	C (27.5)	C (28.4)
	WB	C (29.7)	C (31.1)	D (43.7)	C (29.8)	C (31.5)	D (42.0)	C (26.8)	D (51.8)	C (29.5)	B (16.1)	B (18.3)	B (13.4)
	NB	A (1.8)	A (4.9)	B (12.5)	A (2.7)	A (5.5)	B (14.3)	B (16.9)	A (7.8)	A (7.2)	B (16.6)	A (5.7)	B (17.4)
	SB	A (4.0)	A (7.9)	A (9.0)	A (4.2)	A (8.7)	B (10.2)	B (11.9)	B (11.8)	B (10.4)	B (12.8)	B (14.9)	B (12.9)
	Overall	B (17.1)	B (18.5)	C (27.2)	B (17.5)	B (18.6)	C (26.8)	B (19.9)	C (25.4)	B (18.2)	B (17.6)	B (15.6)	B (18.0)
SC 153 & Rolling Hills Circle / Latham Circle	EB	A (7.9)	A (6.8)	A (9.4)	A (8.7)	A (7.4)	B (10.6)	C (15.2)	A (9.9)	B (11.2)	-	-	-
	WB	A (6.0)	A (9.8)	C (20.1)	A (6.4)	B (11.1)	D (28.3)	B (10.3)	C (18.0)	D (33.9)	-	-	-
	NB	A (6.4)	A (6.5)	A (7.5)	A (6.9)	A (7.1)	A (8.3)	B (13.8)	B (11.4)	A (9.3)	-	-	-
	SB	A (6.1)	A (7.5)	B (14.9)	A (6.5)	A (8.3)	C (18.6)	B (10.0)	B (11.2)	C (20.1)	-	-	-
	Overall	A (6.7)	A (8.2)	C (15.3)	A (7.3)	A (9.2)	C (20.3)	B (12.3)	B (14.0)	C (23.3)	-	-	-
SC 153 & US 123 WB ramp	WB	A (5.0)	A (8.4)	C (18.5)	A (5.3)	A (9.4)	D (25.2)	A (7.8)	B (12.8)	D (27.5)	-	-	-
	NB	A (1.9)	A (3.1)	A (5.4)	A (2.0)	A (3.3)	A (5.9)	A (2.7)	A (4.0)	A (6.1)	-	-	-
	SB	A (7.0)	A (6.5)	A (7.3)	A (7.6)	A (6.9)	A (8.0)	B (11.1)	A (9.7)	A (8.7)	-	-	-
	Overall	A (4.0)	A (4.9)	A (8.9)	A (4.2)	A (5.3)	B (10.9)	A (6.6)	A (7.4)	B (11.7)	-	-	-
SC 153 & Site Access B	EB	-	-	-	-	-	-	-	-	-	-	-	-
	WB	A (8.5)	A (8.1)	A (8.4)	A (8.6)	A (8.2)	A (8.5)	A (9.6)	A (8.9)	A (8.6)	-	-	-
	NB	B (14.2)	C (15.9)	C (20.7)	C (15.0)	C (17.0)	C (23.2)	D (29.7)	D (27.8)	D (26.3)	-	-	-
Rolling Hills Circle & Site Access A	WB	-	-	-	-	-	-	F (234.5)	F (201.8)	C (16.0)	-	-	-
	NB	-	-	-	-	-	-	-	-	-	-	-	-
	SB	-	-	-	-	-	-	A (9.5)	A (9.2)	A (8.1)	-	-	-

The capacity analysis indicates that the traffic signal at US 123 and Prince Perry Road / Rock Springs Road is expected to experience an increase in delays and some drops in level of service with the addition of school traffic. It is recommended to construct dual westbound left turn lanes on US 123 onto Rock Springs Road which would require some widening on Rock Springs Road for an additional receiving lane, most likely to Dayton School Road. With this improvement, all approaches are anticipated to operate at LOS D or better in the AM and SCH peak hours. In the PM peak hour, the mitigated intersection is expected to operate with less delay than the No-Build scenario but would still have an approach operating at LOS E.

The traffic signal at US 123 and Town Center Way would require some adjustments to the coordinated split times to accommodate the addition eastbound left turning traffic which are reflected in the Build Improved scenario. These timing changes are not specifically recommended as mitigation by the development.

At the signalized intersection of Town Center Way and Rolling Hills Circle, the westbound approach is anticipated to experience a drop in level of service in the SCH peak hour with the westbound left turn movement operating at LOS E. As mitigation, it is recommended that protected/permitted left turn phasing be installed for the westbound approach. With this improvement, all approaches are expected to operate at LOS C or better.

Some approaches at the roundabout intersection of SC 153 and Rolling Hills Circle / Latham Road are expected to experience drops in level of service in the Build scenario. However, all approaches would still operate at LOS D or better. No mitigation is recommended.

All approaches at the roundabout intersection of SC 153 and the US 123 Westbound ramps are expected to operate acceptably and similar to the No-Build condition. No mitigation is recommended.

The main student drop-off and pick-up driveway, Access A, is expected to operate at LOS F in the AM and SCH peak hours. This is common for school driveways, and the volumes outside of these 30-minute peak times do not warrant signalization. It is possible that an off-duty police officer could direct traffic during these limited times to limit queuing into the school, but no additional mitigation beyond the warranted turn lanes is recommended.

Figure 9 shows the proposed lane configurations and traffic control for the Build (2028) conditions.

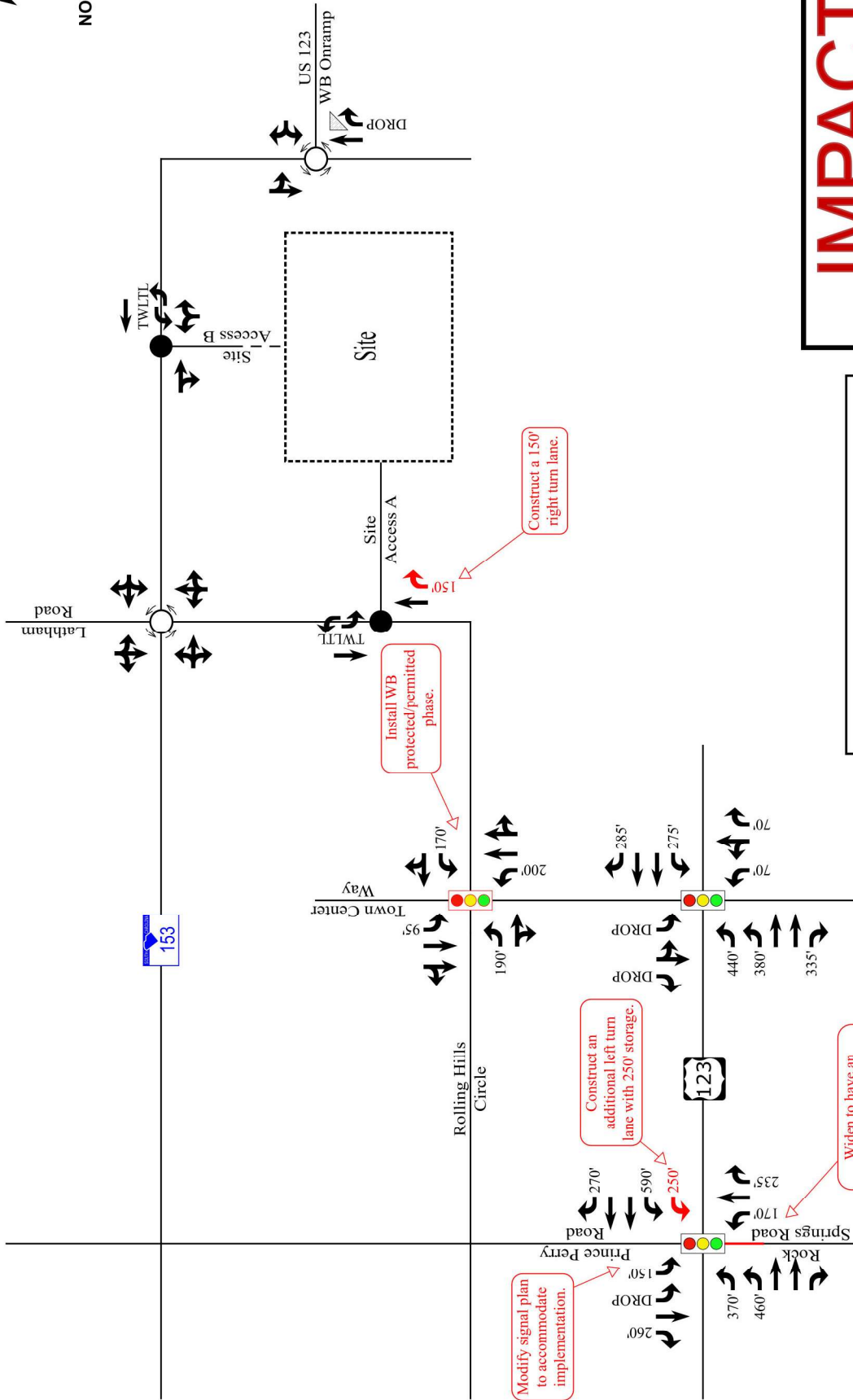

LEGEND

- Signalized Intersection
- Unsignalized Intersection
- Existing Lane
- Recommended Improvement
- Storage (in feet)

IMPACT
Designs, Inc.

Libertas Charter School
Easley, SC

Proposed Lane Configurations
and Traffic Control

Scale: Not to Scale

Figure 9

4. SUMMARY OF FINDINGS

A traffic impact study was conducted for the proposed Libertas Academy Charter School development in accordance with SCDOT guidelines. The proposed development is located south of SC 153, east of Rolling Hills Circle in Easley, SC. The development is expected to consist of a K-8 charter school with a capacity of 1,000 students and 70 faculty members which is expected to be completed by 2028. Direct access to Libertas Academy Charter School development site is proposed to be provided via a full movement access for drop-off and pick-up on Rolling Hills Circle. A secondary shared access with the rental business to the east of the site is proposed to be utilized for the faculty and visitor parking lot.

The study was determined through coordination with SCDOT and consists of the following intersections:

- US 123 and Prince Perry Road / Rock Springs Road
- US 123 and Town Center Way
- Town Center Way and Rolling Hills Circle
- SC 153 and Rolling Hills Circle / Latham Road
- SC 153 and US 123 Westbound Ramps
- SC 153 and Shared Access B
- Rolling Hills Circle and Access A

For the purpose of this analysis, the study intersections listed above were analyzed under the following scenarios:

- Existing (2026) Conditions
- No-Build (2028) Conditions
- Build (2028) Conditions

Traffic operations during the AM, SCH and PM peak hours were modeled for each scenario. The results of each scenario were compared to determine impacts from background traffic growth and the proposed development.

Recommendations:

- Construct a northbound right turn lane on Rolling Hills Circle at Access A with 150 feet of storage and appropriate taper.
- Construct dual westbound left turn lanes on US 123 at Prince Perry Road / Rock Springs Road. The additional left turn lane have at least 250 feet of storage.
- Widen Rock Springs Road for an additional southbound receiving lane extending to Dayton School Road.
- Modify the signal plan at US 123 and Prince Perry Road / Rock Springs Road to accommodate the improvements.
- Install protected/permitted left turn phasing for the westbound approach of Rolling Hills Circle at Town Center Way.